

RISC Core C311 Data Sheet

Summary

The C311 is a member of the C*Core™ High-Performance Low-Power 32-bit RISC core family. It has been designed for high-performance and cost-sensitive embedded applications, with particular emphasis on reduced system power consumption, making it suitable for battery-operated, portable products. The C311 is 100% compatible with the C310 core, which extends the C210 instruction set and functionality by integrating an integer multiplier, branch prediction and folding, improved pipelining of load and store operations, and a deeper instruction buffer to improve memory bandwidth utilization. The C311 can run 33% faster than the C310. The C311 hard macro is available in two versions, one optimized for high performance and one optimized for size and low power.

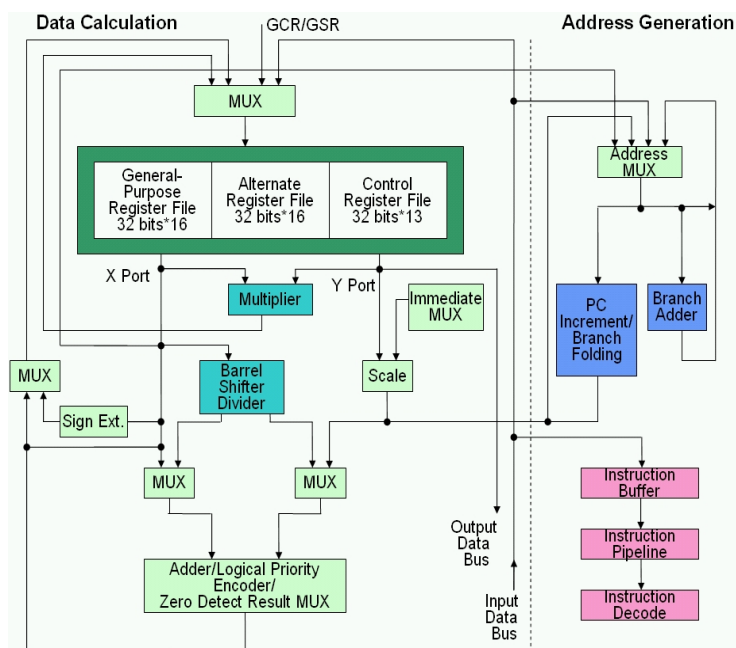

Core Features

- Low power RISC core
- 32-bit load/store architecture
- Highly optimized pipeline
- Single-cycle 32x16 multiplier
- Fixed-length 16-bit instructions
 - † Mostly single-cycle execution
 - † Two-cycle branch execution
- 16 32-bit general purpose registers
- 13 32-bit control registers
- C*Bus MLB bus architecture
 - † Support byte/halfword/word access
 - † Optional AMBA wrapper
- Fast interrupt support
 - † 16 32-bit alternate registers for fast context switching
 - † Vectored/auto-vectored interrupts
 - † 128 interrupt/exception vectors
- Debug support via JTAG-based OnCE™ Design

Performance and Characteristics

Process	Frequency (wcs)	MIPS (wcs)	Size	Power (typ)	Leakage (typ)
HHNEC25 Speed Optimized	90 MHz	86	TBD mm ²	TBD mW/MHz	TBD μW
HHNEC25 Area/Power Optimized	60 MHz	57	TBD mm ²	TBD mW/MHz	TBD μW
SMIC18 Speed Optimized	133 MHz	126	0.628 mm ²	0.50 mW/MHz	30.5 μW
SMIC18 Area/Power Optimized	80 MHz	76	0.604 mm ²	TBD mW/MHz	TBD μW

Application Examples

- Smart Cards
- Consumer Electronics
- Office Automation
- Communication/Network

Availability

- Q2, 2007

To obtain more information about the C311 or other C*CORE™ products, please contact the C*Core Technology Co., Ltd. by phone: 0512-68091372, email: support@china-core.com or web: <http://www.china-core.com>.

C*Core™ is a trade mark of C*Core Co., Ltd.