

RISC Secure RISC Core C310 Data Sheet

Summary

The C310 is a member of the C*Core™ High-Performance Low-Power 32-bit RISC core family. It has been designed for high-performance and cost-sensitive embedded applications, with particular emphasis on reduced system power consumption, making it suitable for battery-operated, portable products. The C310 extends the C210 instruction set and functionality by integrating an integer array multiplier, branch prediction and folding, improved pipelining of load and store operations, and a deeper instruction buffer to improve memory bandwidth utilization.

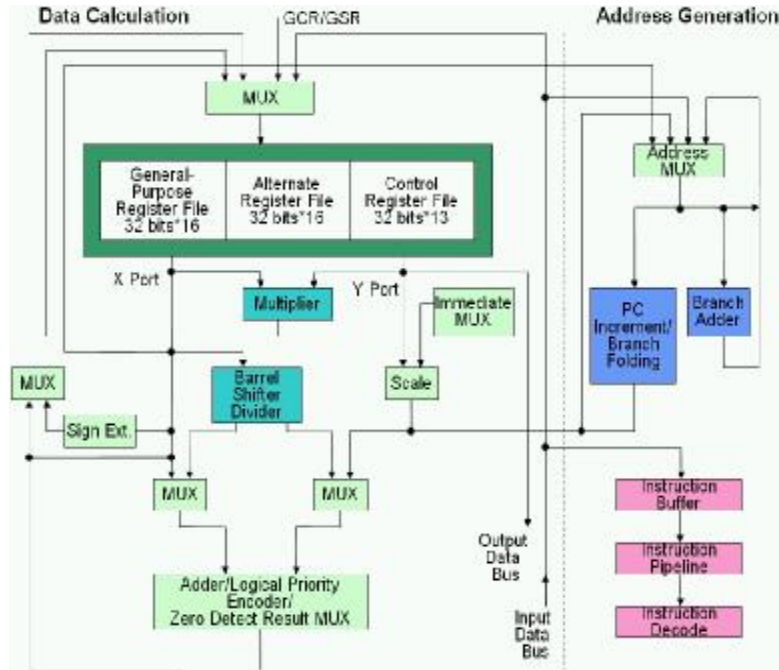

Core Features

- Ø Low power RISC core
- Ø 32-bit load/store architecture
- Ø Highly optimized pipeline
- Ø Single-cycle 32x16 multiplier
 - † Mostly single-cycle execution
 - † Two-cycle branch execution
- Ø Fixed-length 16-bit instructions
 - † 16 32-bit alternate registers for fast context switching
 - † Vectored/auto-vectored interrupts
 - † 128 interrupt/exception vectors
- Ø 16 32-bit general purpose registers
- Ø 13 32-bit control registers
- Ø C*Bus MLB bus architecture
 - † Support byte/halfword/word access
 - † Optional AMBA wrapper
- Ø Fast interrupt support
 - † 16 32-bit alternate registers for fast context switching
 - † Vectored/auto-vectored interrupts
 - † 128 interrupt/exception vectors
- Ø Debug support via JTAG-based OnCE™ Design

Performance and Characteristics

0.18 um process

- Ø Frequency (WCS): 100 MHz (WCS, 1.62V, 125°C)
- Ø Power Consumption: 0.27mW/MHz
- Ø Die Size: 1.0 mm²
- Ø Process: SMIC
- Ø Scale : 260K transistors
- Ø Bus : C*Core Local Bus(CLB)
- Ø Test Method : Mux D Flip-flop Scan Test.

0.25 um process

- Ø Frequency (WCS): 60 MHz
- Ø Power Consumption: 0.46mW/MHz
- Ø Die Size: 1.96 mm²
- Ø Process: HHNEC25 0.25um (WCS, 2.25V, 125°C)
- Ø Scale : 270K transistors

- Ø Bus : C*Core Local Bus(CLB)
- Ø Test Method : Mux D Flip-flop Scan Test.

Application Examples

- Ø Smart Cards
- Ø Consumer Electronics
- Ø Office Automation
- Ø Communication/Network

Availability

- Ø Q2, 2003

*To obtain more information about the C310 or other C*CORE™ products, please contact the C*Core Technology Co., Ltd. by phone: 0512-68091372, email: support@china-core.com or web: <http://www.china-core.com>.*

*C*Core™ is a trade mark of C*Core Co., Ltd.*